

# Retaining Elements

- Flange Adapters
- Adjustable Flange Adapters
- Reducing Adapters
- Reducing Sleeves
- Adaption of Clamping Device
- Special Adapters



## Flange Adapter ZF according to ISO 702-1 (DIN 55028)

### Adaption of clamping device on machine tools

Flange adapter for direct retaining of face driver type FSB on spindle nose DIN ISO 702-1 (DIN 55026) for spindle noses A2 and A1 at the outer bore circle.

Our flange adapters are made of soft steel. This helps to protect the spindle nose and serves for a better damping property. Hardened flange adapters are available upon request.

#### Type ZF with short taper

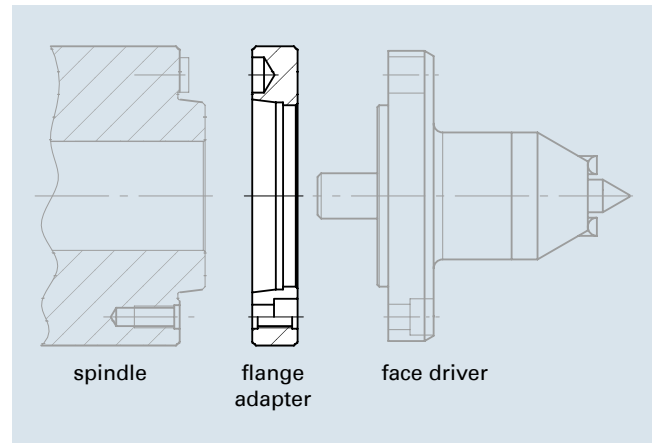
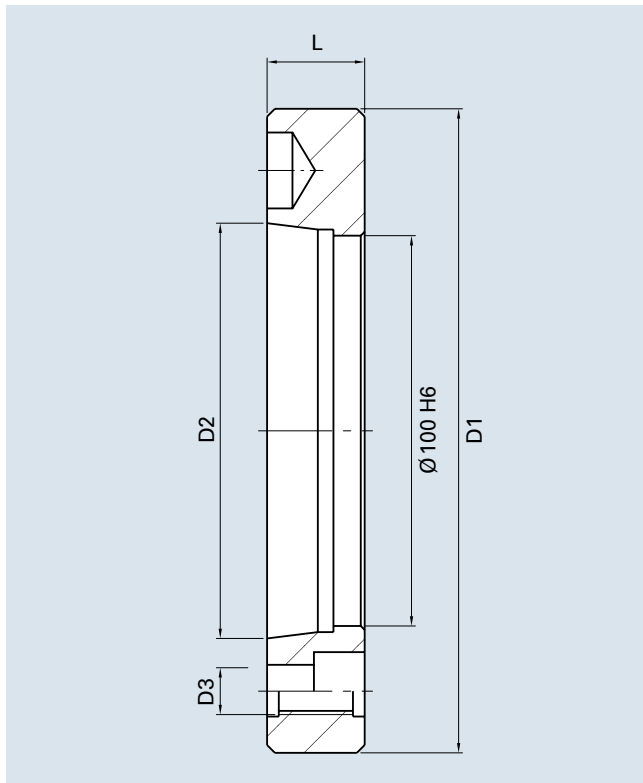

cat. no.	type	spindle size	D1	D2	D3 for	L	for face drivers type FSB
74202	ZF5	5	160	82.563	M10	25	01 - 5
74204	ZF6	6	165	106.375	M12	25	01 - 5
74206	ZF8	8	220	139.719	M16	30	01 - 55
74208	ZF11	11	280	196.869	M20	35	01 - 6

Other sizes and special adapters are available upon request. See also page 7.

Adapters are supplied with mounting screws to suit the machine spindle nose.

## Flange Adapter ZFE according to DIN ISO 702-1 (DIN 55028)

### Adaption of clamping device on machine tools

→ adjustable

Flange adapter for direct retaining of face driver type FFB and FFBH with adjustment true. Adaption on spindle nose DIN ISO 702-1 (DIN 55026) for spindle noses A2 and A1 at the outer bore circle.

Our flange adapters are made of soft steel. This helps to protect the spindle nose and serves for a better damping property. Hardened flange adapters are available upon request.

Type ZFE with short taper

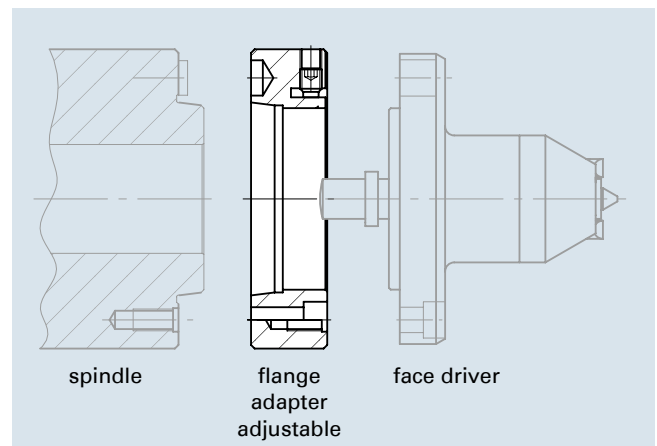
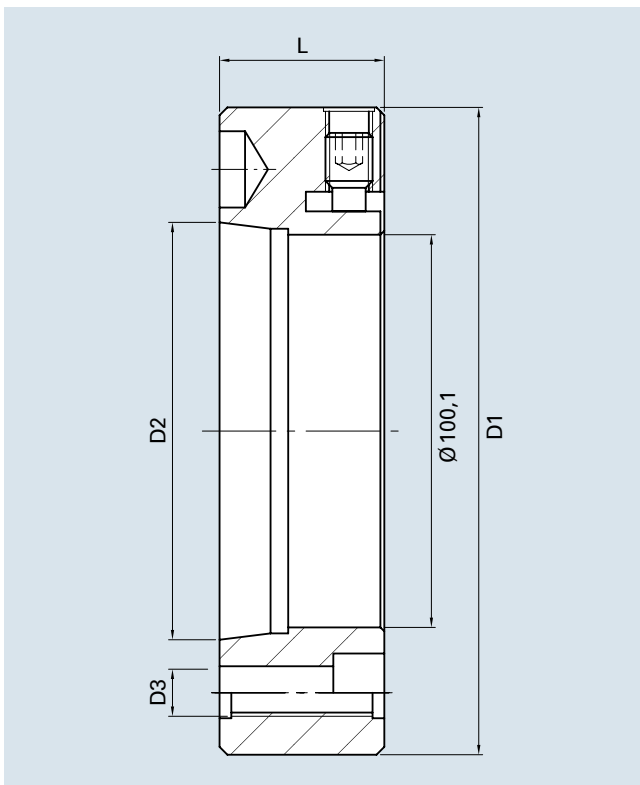

cat. no.	type	spindle size	D1	D2	D3 for	L	for face drivers type FFB/FSB
74212	ZFE5	5	160	82.563	M10	40	01 - 5
74214	ZFE6	6	165	106.375	M12	42	01 - 5
74216	ZFE8	8	220	139.719	M16	42	01 - 55
74218	ZFE11	11	280	196.869	M20	60	01 - 6

Other sizes and special adapters are available upon request. See also page 7.

Adapters are supplied with mounting screws to suit the machine spindle nose.

# Reducing Adapters RF

## Adaption of clamping device on machine tools

Reducing adapter for direct retaining of face driver type SB, pipe driver type NDG or of various center pins with morse taper. Adaption on flange adapter type ZFE or type ZF.

### Type RF with morse taper

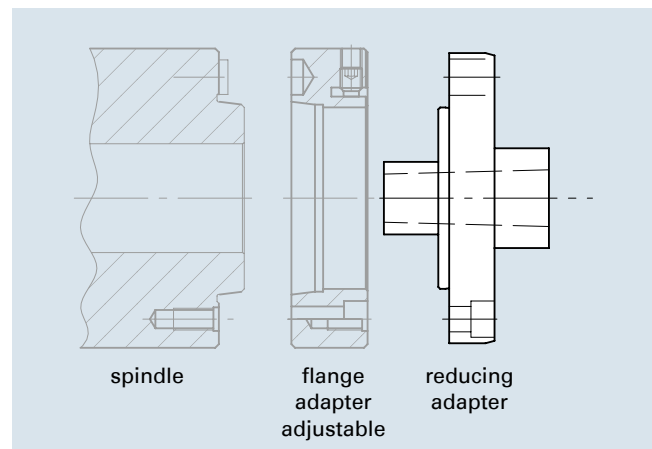
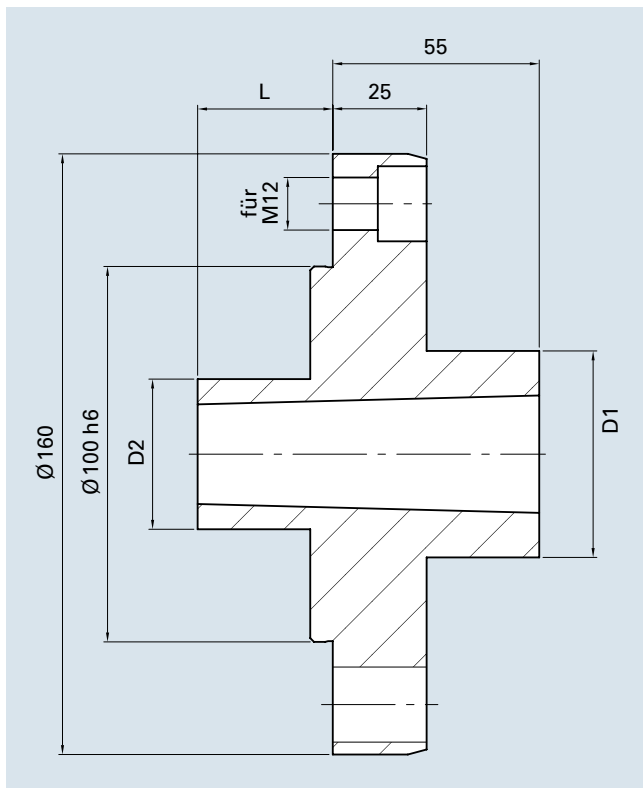

cat. no.	type	MK	D1	D2	L
74301	RF3	3	42	36	15
74302	RF4	4	55	40	36
74303	RF5	5	68	55	63

Other sizes and special adapters are available upon request. See also page 7.

Adapters are supplied with mounting screws to suit the machine spindle nose.



## Reducing Sleeves RH

### Adaption of clamping device on machine tools

Reducing sleeve for retaining of face driver type SB, pipe driver type NDG or of various center pins with morse taper shank. Demounting by means of extraction screw thread.

#### Type RH with morse taper

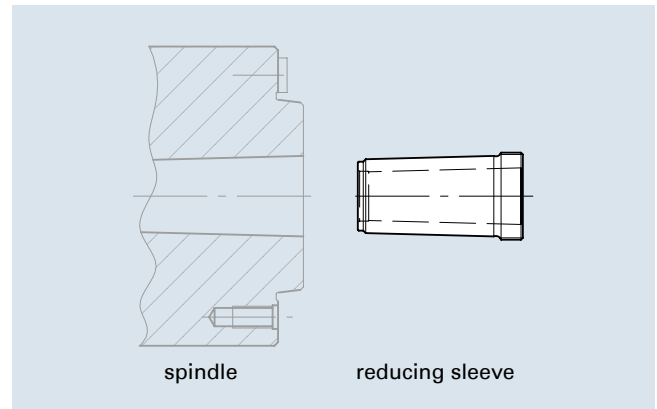
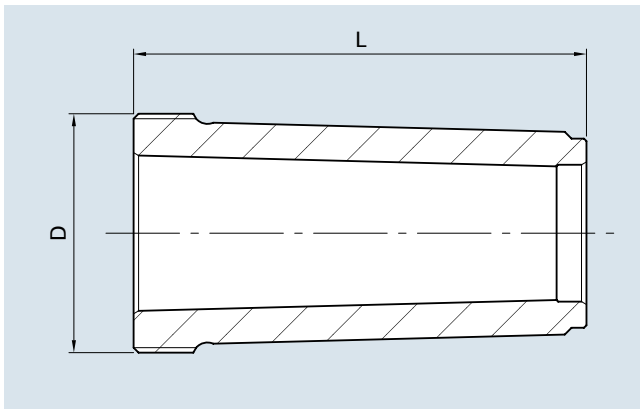

cat. no.	type	MK outside	MK inside	D screw thread	L
93209	RH4/3	4	3	M35 x 1.5	82
93210	RH5/3	5	3	M48 x 1.5	91
93211	RH5/4	5	4	M48 x 1.5	91
93212	RH6/3	6	3	M70 x 1.5	128
93213	RH6/4	6	4	M70 x 1.5	128
93214	RH6/5	6	5	M70 x 1.5	128

Other sizes and special sleeves are available upon request.

### Extracting nut type DIN 1804 h

cat. no.	D1	D2	D3	h
83041	M35 x 1.5	47	55	11
83043	M48 x 1.5	67	75	13
83044	M70 x 1.5	90	100	14

#### Type DIN 1804 h

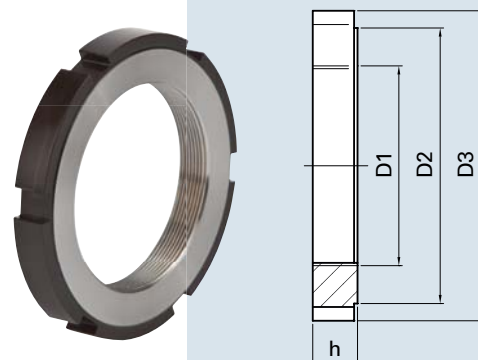

# Adaption of Clamping Device

## Adaption of clamping device on machine tools

### Additional facilities of our face drivers

#### Special face driver type FFB with direct retaining on spindle nose

- minimal set-up time with high true-running properties

#### Face driver type SB can also be clamped at the nose cone using machined jaws

- outer diameter and face side of nose cone are ground

#### Face drivers integrated into retractable jaw chuck

- excellent true-running results and high-performance chipping even with small clamping diameter

#### Face driver type SB with cylindrical shank for retaining of collet

#### Direct retainer

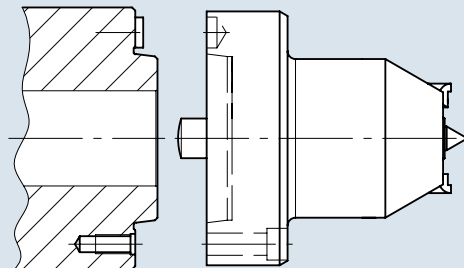

#### Clamping with jaw chuck

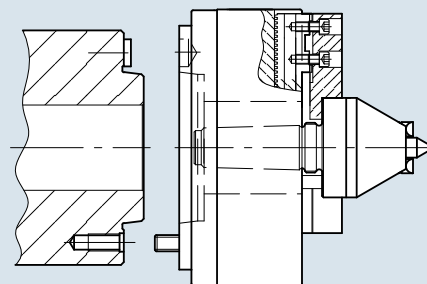

#### Integration into retractable jaw chuck

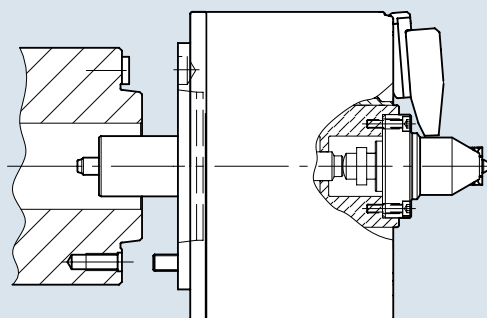

#### Collet

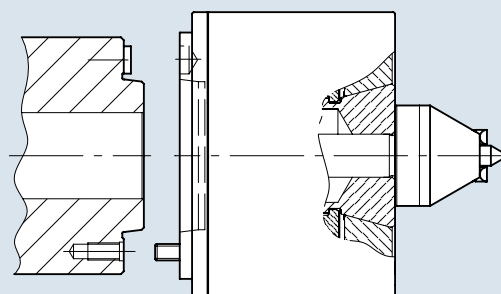

## Special Flange Adapters

### Adaption of clamping device on machine tools

#### Custom-made products

In order to meet the complex requirements of customers and the machine tool industry, we develop and manufacture a variety of special flange adapters.

Our experienced design team develops special flange adapters tailored to your clamping needs and your spindle noses. You communicate your requirements and data to us and we will submit a non-binding offer to you, stating the best possible time of delivery.

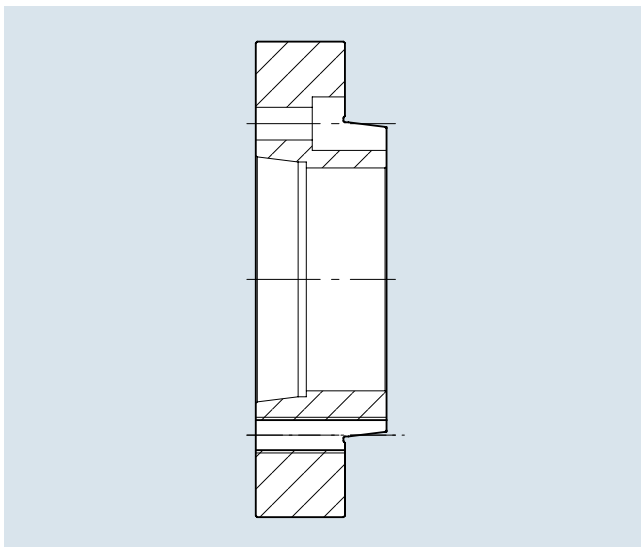

Special SK872-369



for enlarging the spindle nose  
DIN 702-1 (DIN 55026)

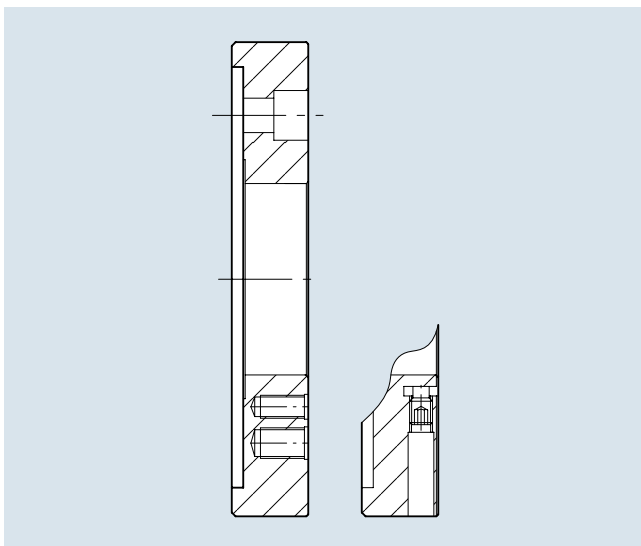

Type ZFE special SK872-232



adjustable flange adapter for  
manufacturer specific spindle nose  
(fig. Gildemeister CTX 500/600)

# Special Flange Adapters

## Adaption of clamping device on machine tools

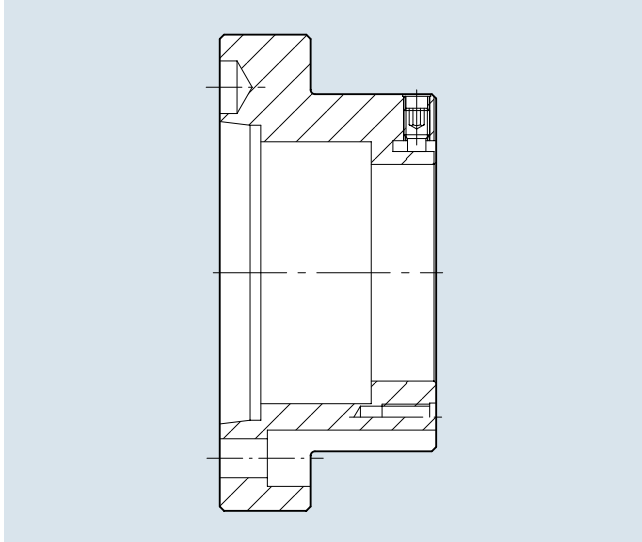

Type ZFE special SK872-374



adjustable flange adapter extended/to maintain the work piece reference at different clamping devices

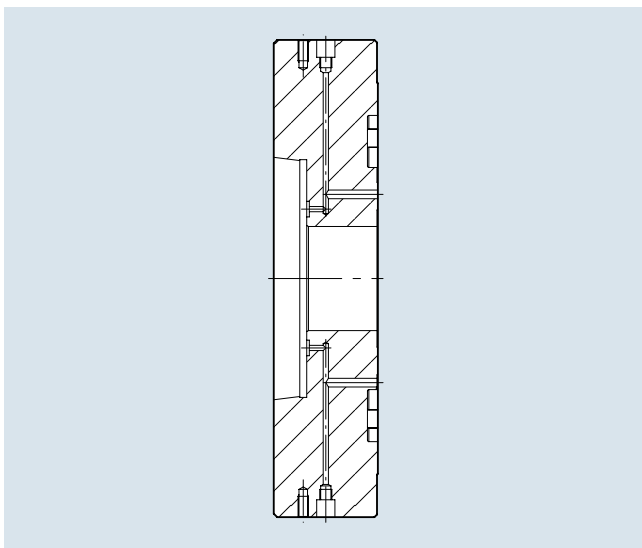

Special SK872-387



for special clamping devices/with control lines for clamping

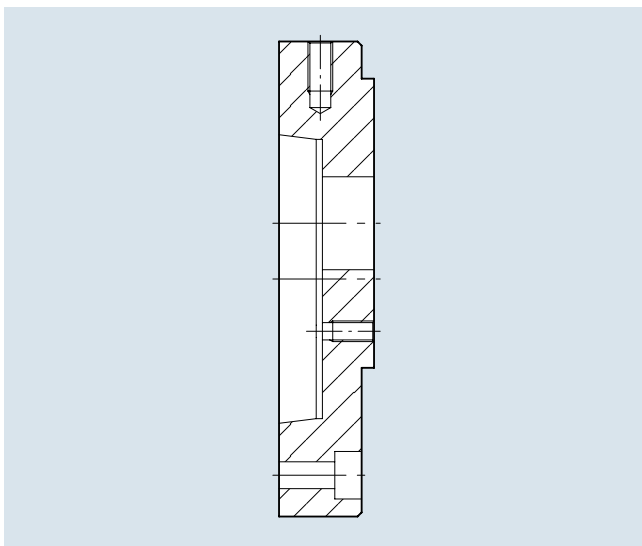

Special SK872-368



with eccentric retainer for special clamping devices